

# ↗ DOMETIC

# MOBILE COOLING

# CFF

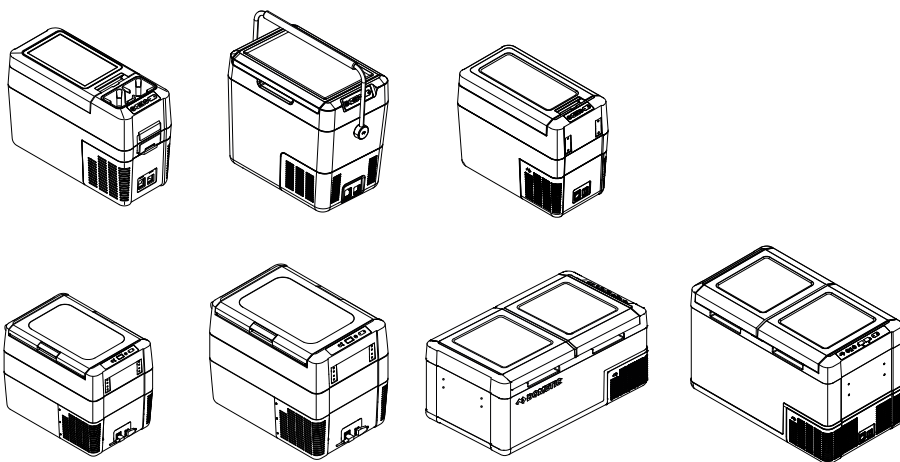

**CFF12, CFF18, CFF20, CFF35, CFF45, CFF50LPDZ, CFF70DZ**

**EN**

**Portable fridge**

Operating Manual.....

## Copyright

© 2024 Dometic Group. The visual appearance of the contents of this manual is protected by copyright and design law. The underlying technical design and the products contained herein may be protected by design, patent or pending patent. The trademarks mentioned in this manual belong to Dometic Sweden AB. All rights are reserved.

# English

1	Important notes.....	3
2	Explanation of symbols.....	3
3	Explanation of symbols on the device.....	4
4	Safety instructions.....	4
5	Scope of delivery.....	6
6	Intended use.....	7
7	Technical description.....	7
8	Before first use.....	11
9	Operation.....	16
10	Cleaning and maintenance.....	23
11	Troubleshooting.....	23
12	Warranty.....	25
13	Disposal.....	25
14	Technical data.....	25

## 1 Important notes

Please read these instructions carefully and follow all instructions, guidelines, and warnings included in this product manual in order to ensure that you install, use, and maintain the product properly at all times. These instructions **MUST** stay with this product.

By using the product, you hereby confirm that you have read all instructions, guidelines, and warnings carefully and that you understand and agree to abide by the terms and conditions as set forth herein. You agree to use this product only for the intended purpose and application and in accordance with the instructions, guidelines, and warnings as set forth in this product manual as well as in accordance with all applicable laws and regulations. A failure to read and follow the instructions and warnings set forth herein may result in an injury to yourself and others, damage to your product or damage to other property in the vicinity. This product manual, including the instructions, guidelines, and warnings, and related documentation, may be subject to changes and updates. For up-to-date product information, please visit [documents.dometic.com](http://documents.dometic.com).

## 2 Explanation of symbols

A signal word will identify safety messages and property damage messages, and also will indicate the degree or level of hazard seriousness.



### **DANGER!**

Indicates a hazardous situation that, if not avoided, will result in death or serious injury.



### **WARNING!**

Indicates a hazardous situation that, if not avoided, could result in death or serious injury.



### **CAUTION!**

Indicates a hazardous situation that, if not avoided, could result in minor or moderate injury.



### **NOTICE!**

Indicates a situation that, if not avoided, can result in property damage.



**NOTE** Supplementary information for operating the product.

### 3 Explanation of symbols on the device



Warning! Risk of fire. Flammable materials.

### 4 Safety instructions



#### **DANGER! Electrocutation hazard**

- > On boats: If the device is powered by the mains, ensure that the power supply has a residual current device (RCD), a residual current circuit breaker (RCCB), or a ground fault circuit interrupter (GFCI). Installation, especially in potentially damp areas, must be in accordance with all applicable installation regulations.
- > Do not touch exposed cables with your bare hands. This applies especially when operating the device from the AC mains.
- > Before starting the device, ensure that the power supply line and the plug are dry.



#### **WARNING! Explosion hazard**

Do not store any explosive substances such as spray cans with a flammable propellant in the cooling device.



#### **WARNING! Electrocutation hazard**

- > Do not operate the cooling device if it is visibly damaged.
- > If the cooling device's power cable is damaged, it must be replaced with a suitable power cable or assembly available from the manufacturer or its service agent to prevent safety hazard.
- > This cooling device may only be repaired by qualified personnel. Improper repairs can lead to considerable hazards.
- > Plug the device to sockets that ensure proper connection especially when the device needs to be earthed.



#### **WARNING! Fire hazard**

- > When positioning the cooling device, ensure that the supply cord is not trapped or damaged.
- > Do not locate multiple portable socket-outlets or portable power supplies at the rear of the device.
- > In the event of any damage to the refrigerant circuit:
  - Keep open flames and potential ignition sources away from the cooling device.
  - Ventilate the room well.
  - Switch off the cooling device.
- > For cooling devices with flammable refrigerant: The refrigeration circuit contains a small quantity of an environmentally friendly but flammable refrigerant. It does not damage the ozone layer and does not increase the greenhouse effect. Any leaking refrigerant may ignite.
- > Keep the ventilation openings on the device housing or in installations free of obstructions.
- > Do not use any mechanical objects or other means to speed up the defrosting process, unless they have been recommended by the manufacturer for this purpose.
- > Do not open or damage the refrigerant circuit.
- > Do not use electrical devices inside the cooling device unless they are recommended by the manufacturer for that purpose.

**WARNING! Health hazard**

- > This cooling device is not intended for use by persons (including children) with reduced physical, sensory or mental capabilities, or lack of experience and knowledge, unless they have been given supervision or instruction concerning use of the cooling device by a person responsible for their safety.
- > Children must be supervised to ensure that they do not play with the device.
- > Cleaning and user maintenance must not be carried out by unsupervised children.

**CAUTION! Electrocutation hazard**

- > Before starting the cooling device, ensure that the power supply line and the plug are dry.
- > Disconnect the cooling device from the power supply
  - Before each cleaning and maintenance
  - After every use

**CAUTION! Health hazard**

- > To avoid contamination of food, observe the following instructions:
  - Check if the cooling capacity of the cooling device is suitable for storing the food to be cooled.
  - Food may only be stored in its original packaging or in suitable containers.
  - Opening the cooling device for long periods of time can cause significant increase of the temperature in the compartments of the device.
  - Clean regularly surfaces that can come in contact with food and accessible drainage systems.
- > If the cooling device is left empty for long periods:
  - Switch off the cooling device.
  - Defrost the cooling device.
  - Clean and dry the cooling device.
  - Leave the lid open to prevent mold from developing within the cooling device.

**NOTICE! Damage hazard**

- > Check that the voltage specification on the data plate corresponds to that of the energy supply.
- > Only connect the cooling device as follows:
  - With the DC connection cable to a DC power supply in the vehicle
  - With the AC connection cable to an AC power supply
- > Never pull the plug out of the socket by the cable.
- > If the cooling device is connected to a DC outlet, disconnect the cooling device and other power consuming devices from the battery before connecting a quick charging device.
- > If the cooling device is connected to a DC outlet, disconnect the cooling device or switch it off when turning off the engine. Otherwise the battery may be discharged.
- > The cooling device is not suitable for transporting caustic materials or materials containing solvents.
- > The insulation of the cooling device contains flammable cyclopentane and requires special disposal procedures. Deliver the cooling device at the end of its life-cycle to an appropriate recycling center.
- > Do not place the cooling device near open flames or other heat sources (heaters, direct sunlight, gas ovens, etc.).
- > **Risk of overheating!** Ensure at all times that there is a minimum of 50 mm ventilation on all sides of the cooling device. Keep the ventilation area free of any objects that could obstruct the air flow to the cooling components. Do not use or store the cooling device in closed compartments or areas with none or minimal air flow.
- > Do not fill the inner container with ice or fluids.
- > Never immerse the cooling device in water.
- > Protect the cooling device and cables against heat and moisture.

> The cooling device shall not to be exposed to rain.

## 5 Scope of delivery

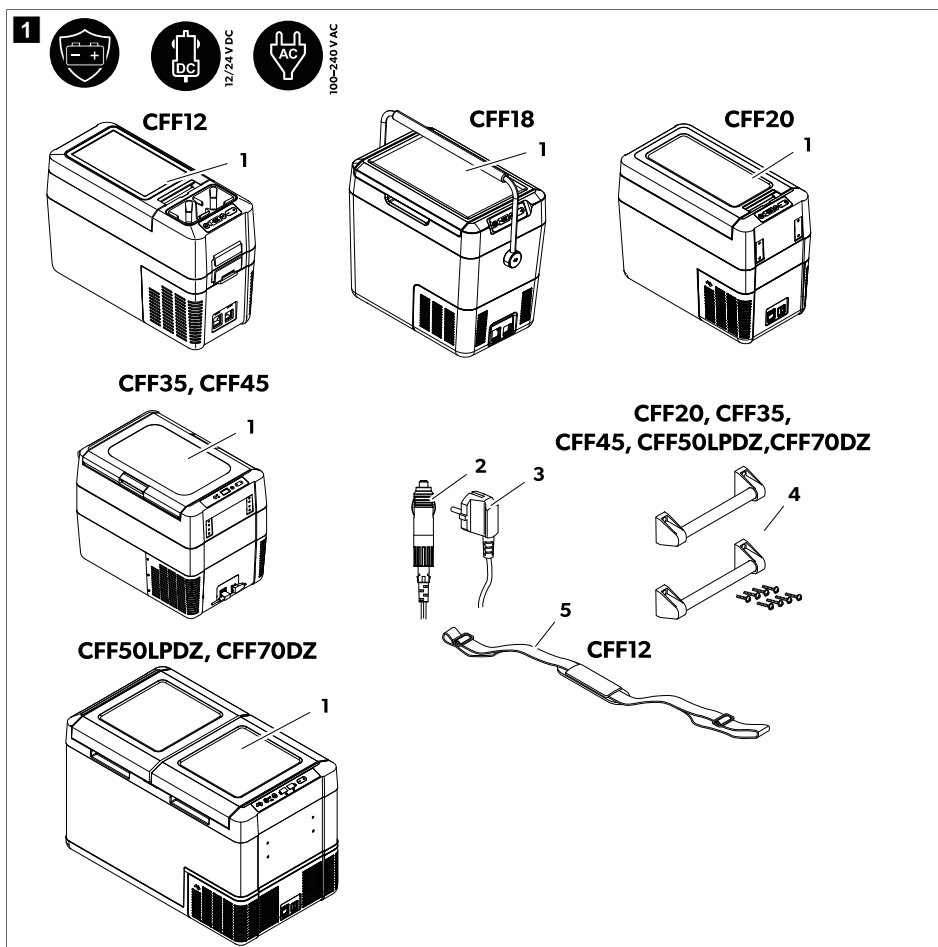

Item in  Fig. 1 on page 6	Quantity	Description
1	1	Cooler
2	1	Connection cable for DC connection
3	1	Connection cable for AC connection

Item in  Fig. 1 on page 6	Quantity	Description
4	2	<b>CFF20, CFF35, CFF45, CFF50LPDZ, CFF70DZ only:</b> Carry handle set, consisting of: <ul style="list-style-type: none"> <li>• 4 holders (CFF20 only)</li> <li>• 2 handles</li> <li>• 8 fastening screws</li> <li>• 1 Allen wrench</li> </ul>
5	1	<b>CFF12 only:</b> Shoulder strap
–	1	Operating manual

## 6 Intended use

The cooling device is suitable for cooling food. The cooling device is also suitable for use on vehicles.

The cooling device is designed to be operated from a DC on-board power supply of a vehicle or boat, from a DC auxiliary battery or from an AC power supply.

The cooling device is suitable for camping or other similar recreational uses.

The cooling device is intended to be used in household and similar applications such as:

- Staff kitchen areas in shops, offices and other working environments
- Farm houses
- Clients in hotels, motels and other residential type environments
- Bed and breakfast type environments
- Catering and similar non-retail applications

This product is only suitable for the intended purpose and application in accordance with these instructions.

This manual provides information that is necessary for proper installation and/or operation of the product. Poor installation and/or improper operation or maintenance will result in unsatisfactory performance and a possible failure.

The manufacturer accepts no liability for any injury or damage to the product resulting from:

- Incorrect installation, assembly or connection, including excess voltage
- Incorrect maintenance or use of spare parts other than original spare parts provided by the manufacturer
- Alterations to the product without express permission from the manufacturer
- Use for purposes other than those described in this manual

Dometic reserves the right to change product appearance and product specifications.

## 7 Technical description

A low maintenance refrigerant circuit with compressor provides the cooling. The generous insulation and the powerful compressor ensure efficient and fast cooling.

The cooling device is portable.

The cooling device can withstand a short-term inclination of 30°, for example on boats.

## 7.1 Scope of functions

- Power supply with priority circuit for connecting to the AC power supply
- Three-level battery monitor to protect the vehicle battery (switches off automatically at low battery voltage)
- Display with temperature gauge in °C and °F
- Temperature setting: In steps of 1 °C (1 °F)
- Display dimming function with 3 brightness levels
- Removable cup holder **(CFF12 only)**
- Removable divider **(CFF18 only)**
- Removable wire basket **(CFF35, CFF45, CFF50LPDZ, CFF70DZ only)**
- Removable carry handles **(CFF20, CFF35, CFF45, CFF50LPDZ, CFF70DZ only)**



## 7.2 Operating and display elements

### Lid latches

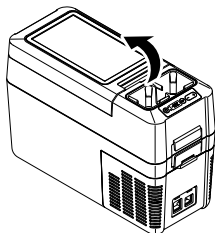
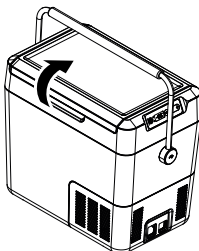
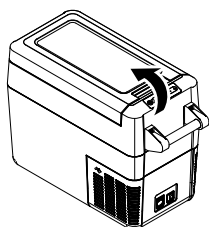
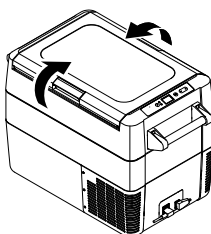
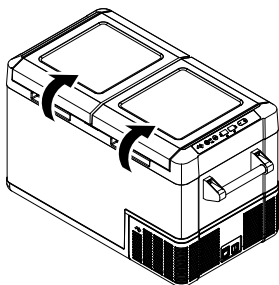
**2****CFF12****CFF18****CFF20****CFF35, CFF45****CFF50LPDZ, CFF70DZ**

Operating panel

**3** CFF12, CFF18  
CFF20

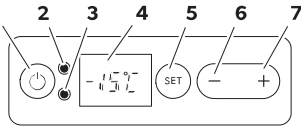

CFF35, CFF45

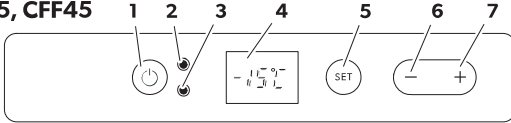

CFF50LPDZ, CFF70DZ

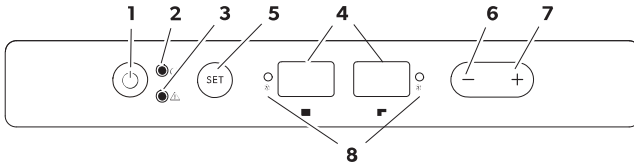

Item	Description	Explanation
1		Switches the cooling device on or off when the button is pressed for between one and two seconds
2		Status indication LED lights up green: Compressor is on LED lights up orange: Compressor is off LED flashes orange: Display switched off automatically due to low battery voltage
3	ERROR	LED flashes red: Device is switched on but not ready for operation
4	-	Display, shows the information <b>Dual zone (DZ):</b> There's one display per zone
5	<b>SET</b>	Selects the input mode <ul style="list-style-type: none"> <li>• Temperature setting</li> <li>• Celsius or Fahrenheit display</li> <li>• Set battery monitor</li> <li>• Set brightness of display</li> </ul>
6	-	Press once to decrease the value
7	+	Press once to increase the value
8		<b>Dual zone (DZ):</b> Status indication: LED lights up blue when the compartment is cooling

## Connection sockets

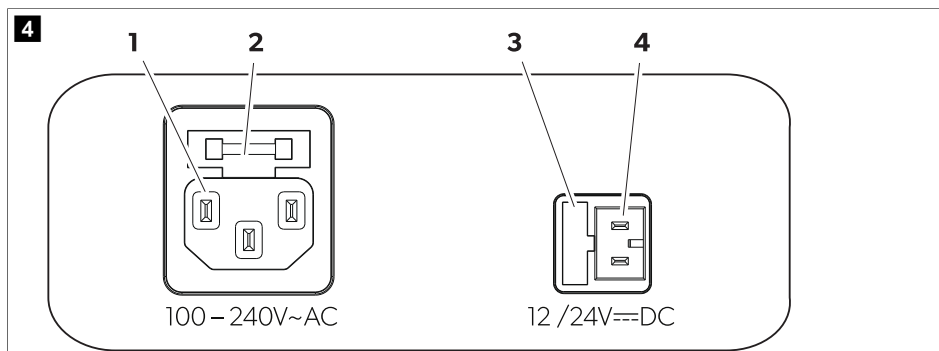

Item	Description
1	Connection socket AC voltage supply
2	AC fuse holder
3	DC fuse cover
4	Connection socket DC voltage supply

## 8 Before first use



**NOTE** Before starting the cooling device for the first time, clean it inside and outside with a damp cloth for hygienic reasons (see *Cleaning and maintenance* on page 23).

### Mounting the handles

1. CFF20: Assemble a handle by putting two holders **(1)** and a handle **(2)** together. Fasten the holders with the enclosed screws in the holes provided.
2. CFF35, CFF45, CFF50LPDZ, CFF70DZ: Fasten the handle with the enclosed screws in 2 of the round holes.

5

CFF20

CFF35, CFF45

CFF50LPDZ, CFF70DZ

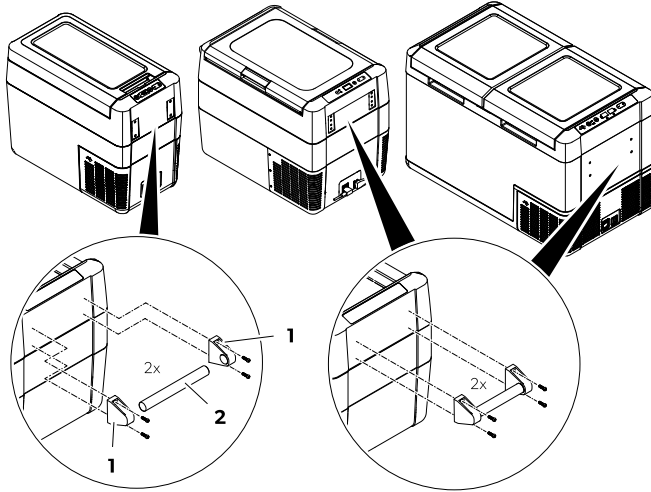

3. Fasten the handle with the enclosed screws in 2 of the waist shaped holes.

## Reversing the lid opening (Dual Zone only)

6

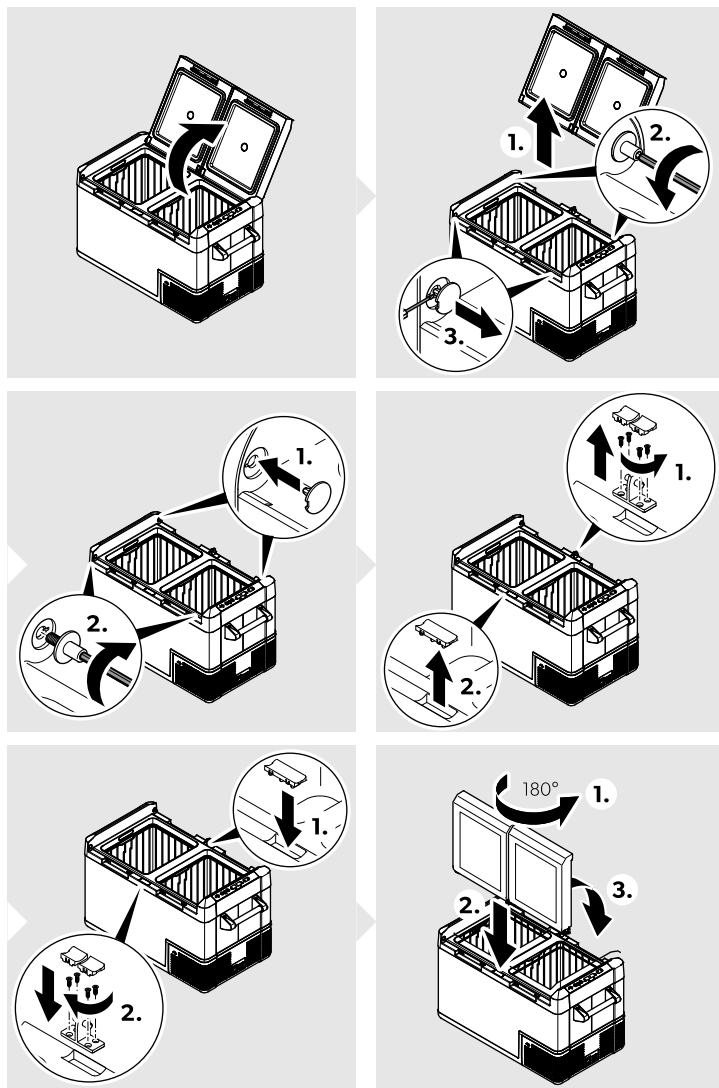

> To reverse the lid opening proceed as shown ( Fig. 6 on page 13).

### Opening or removing the lid

**7**

**CFF12**

**A**

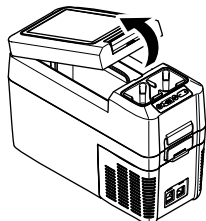

**2.**

**B**

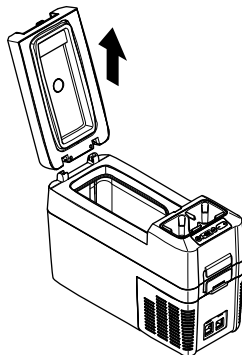
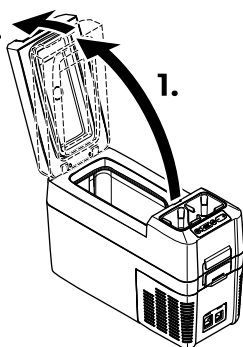

**CFF18**

**A**

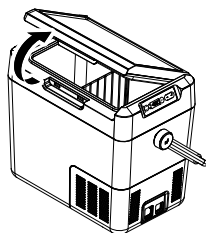

**B**

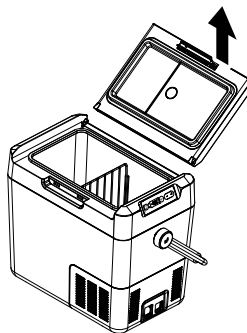
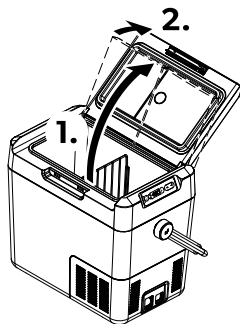

**CFF20**

**A**

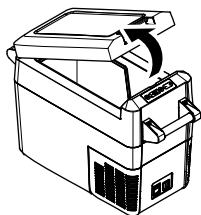

**B**

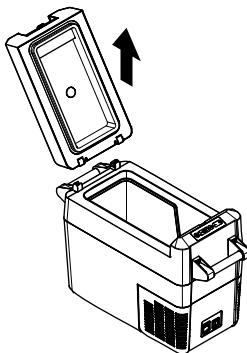
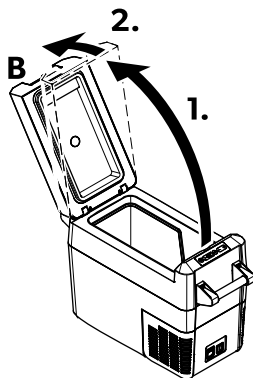

**CFF35, CFF45**

**A**

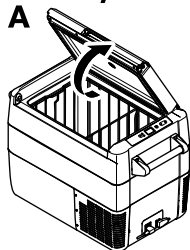

**B**

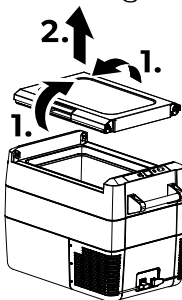
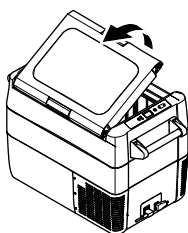

- > To open the lid unlatch **(A)**.  
**CFF35, CFF45:** The lid can be opened from either side.
- > **CFF35, CFF45:** To remove the lid, unlatch both sides at the same time **(B)**.
- > **CFF12, CFF18, CFF20, CFF50LPDZ, CFF70DZ:** Push the lid beyond the lid stop position **(B)**.

### Lid stop position

The lid has a built-in stop position **(A)**. Do not force the lid past the built-in stop **(B)**.

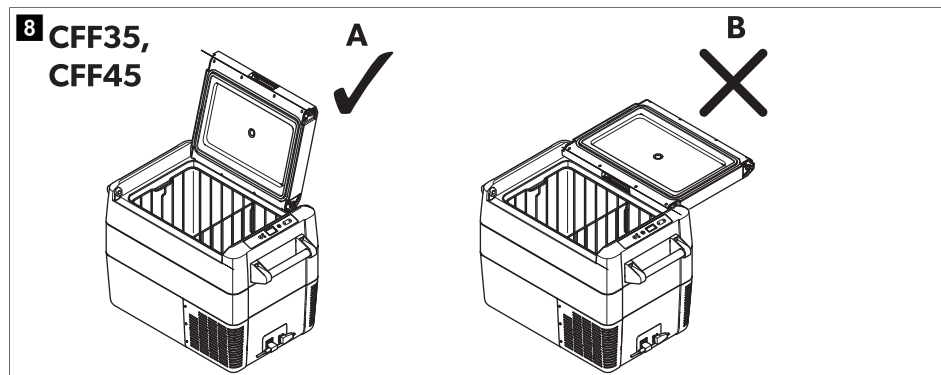

#### NOTICE! Damage hazard

If the lid has been forced too far, follow the steps described in Lid past built-in stop (CFF35, CFF45) on page 24.

### Removing the cup holder (CFF12 only)

- > Lift the cup holder out to access a convenient storage area.

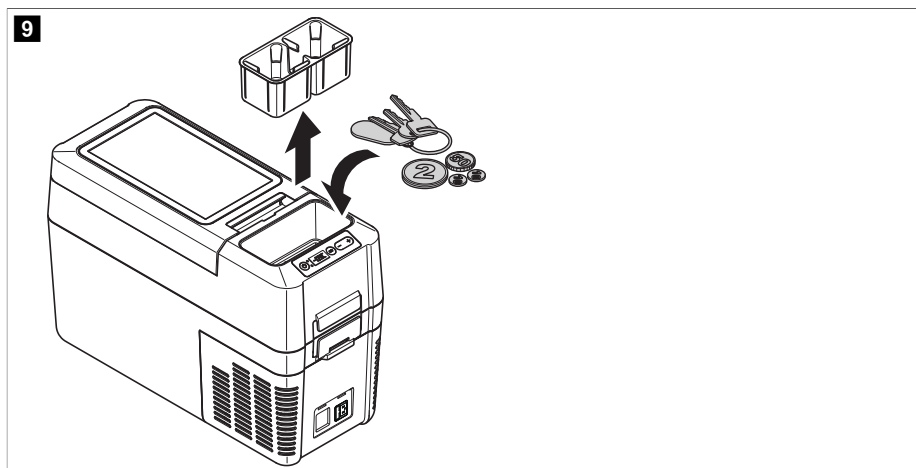

## Removing the basket (CFF35 and CFF45 only) and divider (CFF18 only)



### NOTICE! Damage hazard

Removing the basket with the lid open may scratch the lid and deform the basket. It is recommended to remove the lid before removing the basket.

> Proceed as shown (  Fig. 10 on page 16).

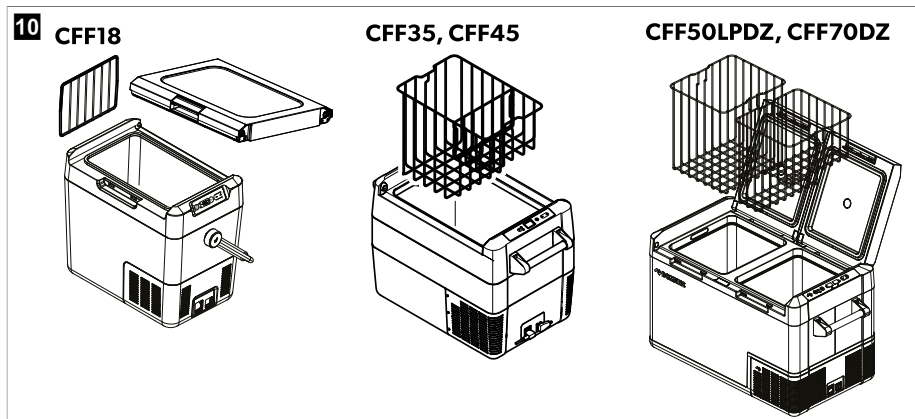

## Selecting the temperature units

Temperature display units can be switched between Celsius and Fahrenheit as follows:

1. Switch on the cooling device.
  2. Press the **SET** button:
    - a) **CFF12, CFF18, CFF20, CFF35, CFF45:** Twice.
    - b) **CFF50LPDZ, CFF70DZ:** Three times.
  3. Use the **+** or **-** buttons to select Celsius or Fahrenheit.
- ✓ The selected temperature unit then appears in the display for a few seconds. The display flashes several times before it returns to the current temperature.

## 9 Operation

### 9.1 Avoiding food waste

To avoid food waste, note the following

- > Keep temperature fluctuation as low as possible. Only open the cooling device as often and for as long as necessary. Store the foodstuff in such a way that the air can still circulate well.
- > Adjust the temperature to the quantity and type of the foodstuff.
- > Foodstuff can easily absorb or release odor or taste. Always store foodstuff covered or in closed containers/ bottles.

### 9.2 Saving energy

- > Choose a well ventilated location which is protected from direct sunlight.



- > Allow warm food to cool down first before placing it in the cooling device to keep cool.
- > Do not open the cooling device more often than necessary.
- > Do not leave the cooling device open for longer than necessary.
- > If the cooling device has a basket: For optimal energy consumption, position the basket according to its position on delivery.
- > On a regularly basis, ensure the lid seal still fits properly.
- > Avoid unnecessarily low temperatures.

### 9.3 Connecting the cooling device



#### Connecting to a battery (vehicle or boat)

The cooling device can be operated with 12 V $\overline{=}$  or 24 V $\overline{=}$ . For safety reasons the cooling device is equipped with an electronic system to prevent polarity reversal. This protects the cooling device against short-circuiting when connecting to a battery.



#### **NOTICE! Damage hazard**



For protection of the device the DC cable supplied includes a fuse inside the plug. Do **not** remove the fused DC plug. Only use the DC cable supplied.

1. Plug the DC connection cable (  Fig. 1 on page 6 2) into the DC voltage socket of the cooling device (  Fig. 4 on page 11 4).
2. Connect the connection cable to a DC power outlet.

#### Connecting to an AC power supply

The cooling device has an integrated multi-voltage power supply with priority circuit for connecting to an AC voltage source. The priority circuit automatically switches the cooling device to AC operation if the device is connected to an AC power supply, even if the DC connection cable is still attached.

When switching between the AC power supply and the battery supply, the red LED may light up briefly.

1. Plug the AC connection cable (  fig. 1 3) into the AC voltage socket of the cooling device (  fig. 4 1).
2. Connect the connection cable to an AC power outlet.

### 9.4 Using the battery monitor

The cooling device is equipped with a multi-level battery monitor that protects the vehicle battery against excessive discharging when the cooling device is connected to the on-board DC supply.

If the cooling device is operated when the vehicle ignition is switched off, the cooling device switches off automatically as soon as the supply voltage falls below a set level. The cooling device will switch back on once the battery has been recharged to the restart voltage level.



#### **NOTICE! Damage hazard**

When switched off by the battery monitor, the battery will no longer be fully charged. Avoid starting repeatedly or operating current consumers without longer charging phases. Ensure that the battery is recharged.

In the "HIGH" mode the battery monitor responds faster than in the LOW and MED modes (see the following table).

Battery monitor mode	LOW	MED	HIGH
Switch-off voltage at 12 V	10.1 V	11.2 V	11.8 V
Restart-voltage at 12 V	11.4 V	12.2 V	12.6 V
Switch-off voltage at 24 V	21.5 V	24.1 V	24.6 V
Restart voltage at 24 V	23 V	25.3 V	26.2 V

The battery monitor mode can be selected as follows:

1. Switch on the cooling device.
  2. Press the **SET** button three times.  
For dual zone cooling devices, press the **SET** button four times.
  3. Use the **+** or **-** buttons to select the battery monitor mode.
- ✓ The display shows the selected mode for a few seconds: **Lo** (LOW), **Med** (MEDIUM), **Hi** (HIGH)

The display flashes several times before it returns to the current temperature.



**NOTE** When the cooling device is supplied by the starter battery, select the battery monitor mode "HIGH". If the cooling device is connected to a supply battery, the battery monitor mode "LOW" will suffice.

## 9.5 Using the cooling device



### **NOTICE! Risk of overheating**

Ensure at all times that there is sufficient ventilation so that the heat that generated during operation can dissipate. Ensure that the ventilation slots are not covered. Ensure that the device is sufficiently far away from walls and other objects so that the air can circulate.



### **NOTICE! Damage hazard from excessively low temperature**

Ensure that only those objects are placed in the cooling device that are intended to be cooled at the selected temperature.



### **NOTICE! Damage hazard**

Place the cooling device as shown (  Fig. 1 on page 6 1). If you operate the cooling device in a different orientation, it can be damaged.



**NOTE** When operating with the battery, the display switches off automatically if the battery voltage is low. The  LED flashes orange.

Before first use on page 11

1. Place the cooling device on a firm foundation.
2. Connect the cooling device (see Connecting the cooling device on page 17).
3. Press the  button for between one and two seconds.

✓ The  LED lights up.

The display (  Fig. 3 on page 10 4) switches on and shows the current temperature.

The cooling device starts cooling the interior.

## Latching the cooling device lid



### NOTE

- > **CFF35, CFF45:** When latching the lid, ensure that both latch side pins are fully engaged to ensure a good lid seal. One latch may engage slightly before the other.
- > If the lid is not closed equally at both sides, press until a second click is heard.

1. Close the lid.
2. Press the latch (  Fig. 2 on page 9) down until it latches in place audibly

## 9.6 Fixing the cooling device while transporting (CFF12 only)



### WARNING! Risk of injury

Ensure that the cooling device is fixed correctly. Otherwise it could be dislodged and cause severe injuries to passengers when a hard break occurs.

When transporting the cooling device in a vehicle, you can fix the device with the safety seat belt or with luggage tighteners so that it remains in its position.

- > When fixing with a **safety seat belt** proceed as shown (  Fig. 11 on page 19).

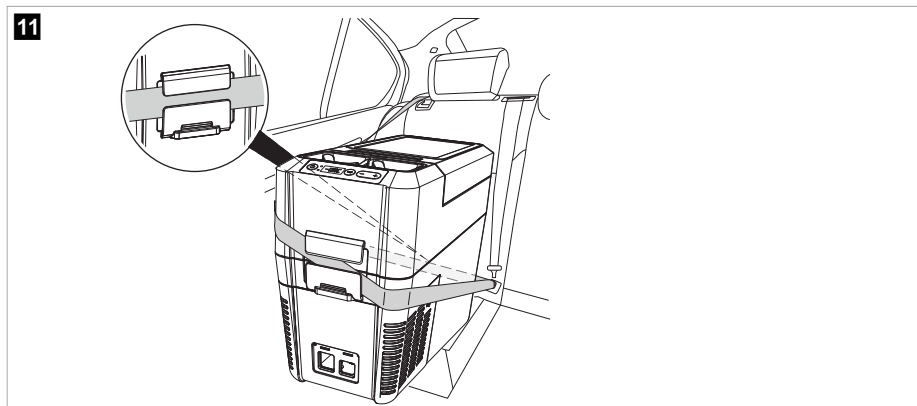

- > When fixing with **luggage tighteners** proceed as shown (  Fig. 12 on page 20).

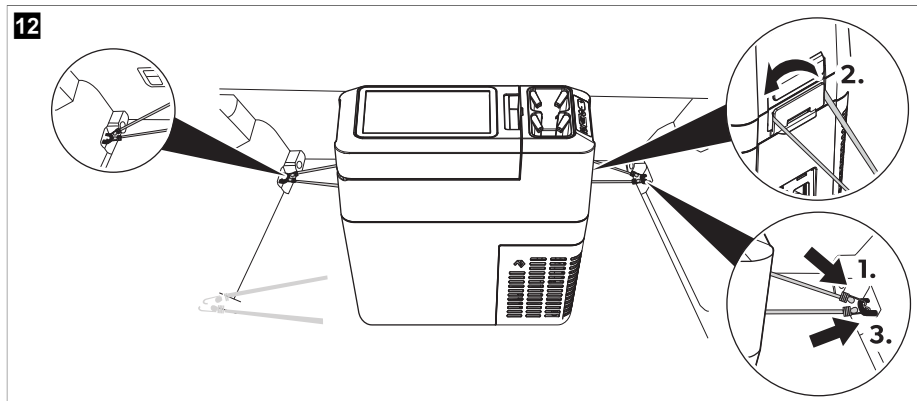

## 9.7 Setting the temperature

- > Press the **SET** button once.
- > Use the **+** and **-** buttons to select the cooling temperature.
- ✓ The cooling temperature appears in the display for a few seconds. The display flashes several times and then the current temperature is displayed again.

### Dual zone cooling devices

1. Press the **SET** button once for the large compartment or twice for the small compartment.
  - ✓ The chosen compartment's display blinks.
2. Use the **+** and **-** buttons to select the cooling temperature.
 

Each compartment can be set to work as a refrigerator or a freezer compartment.

  - ✓ The cooling temperature appears in the chosen compartment's display for a few seconds. The display flashes several times and then the current temperature is displayed again.

## 9.8 Switching a compartment off or on (dual zone cooling devices)

If only one compartment is required, the other compartment can be switched off to save energy.

### Switching off a compartment

1. Press the **SET** button once for the large compartment or twice for the small compartment.
  - ✓ The chosen compartment's display blinks.
2. Press the  button.
  - ✓ **OFF** flashes for five seconds on the display of the respective cooling compartment, then **OFF** is displayed.

### Switching on a compartment

If the display of the compartment shows **OFF**, you can switch on the compartment as follows:

1. Press the **SET** button once for the large compartment or twice for the small compartment.
  - ✓ The chosen compartment's display blinks.
2. Press the  button.

- ✓ The cooling temperature appears in the display for a few seconds. The display flashes several times and then the current temperature is displayed.

## 9.9 Setting the display brightness

The display brightness can be dimmed for low ambient light conditions.

To set the dimming level of the display proceed as follows:

1. Switch on the cooling device.
  2. Press the **SET** button four times.  
For dual zone cooling devices, press the **SET** button five times.
  3. Use the **+** and **-** buttons to set the brightness of the display.
- ✓ The display will show as follows: **d0** (default), **d1** (medium), **d2** (dark).

The display shows the set mode for several seconds. The display flashes twice before it returns to the current temperature.



**NOTE** The displays' factory setting of brightness is **d0**.

If a fault occurs, the brightness automatically reverts to brightness **d0**. After troubleshooting the set brightness is reactivated.

## 9.10 Switching off the cooling device

1. Empty the cooling device.
2. Switch the cooling device off.
3. Pull out the connection cable.

If you do not want to use the cooling device for a longer period of time: Leave the lid slightly open. This prevents odor build-up.

## 9.11 Defrosting the cooling device

Humidity can form frost in the interior of the cooling device or on the evaporator. This reduces the cooling capacity.



### **NOTICE! Damage hazard**

Never use hard or pointed tools to remove ice or to loosen objects which have frozen in place.

To defrost the cooling device proceed as follows:

1. Remove the contents of the cooling device.
2. If necessary, place the contents in another cooling device to keep them cold.
3. Switch off the cooling device.
4. Leave the lid open.
5. Wipe off defrosted water.

## 9.12 Replacing the AC fuse



### **DANGER! Electrocutation hazard**

Disconnect the power supply and the connection cable before you replace the device fuse.

1. Disconnect the power supply to the device.
2. Remove the connection cable.
3. Pry out the fuse insert (  Fig. 3 on page 10) with a screwdriver.
4. Replace the defective glass fuse with a new one of the same type and rating (4 A, 250 V).
5. Press the fuse insert back into the housing.
6. Reconnect the power supply to the device.

## 9.13 Replacing the DC fuse

1. Disconnect the power supply to the cooling device.
2. Pry out the fuse cover (  Fig. 3 on page 10) with a screwdriver.
3. Reverse the fuse cover and use hook to remove the defective blade fuse.
4. Push in a new fuse of the same type and rating.
5. Re-fit the fuse cover.
6. Reconnect the power supply to the cooling device.

## 9.14 Replacing the DC plug fuse

- > Replace the defective fuse with a new fuse of the same type and rating as shown (  Fig. 13 on page 22).

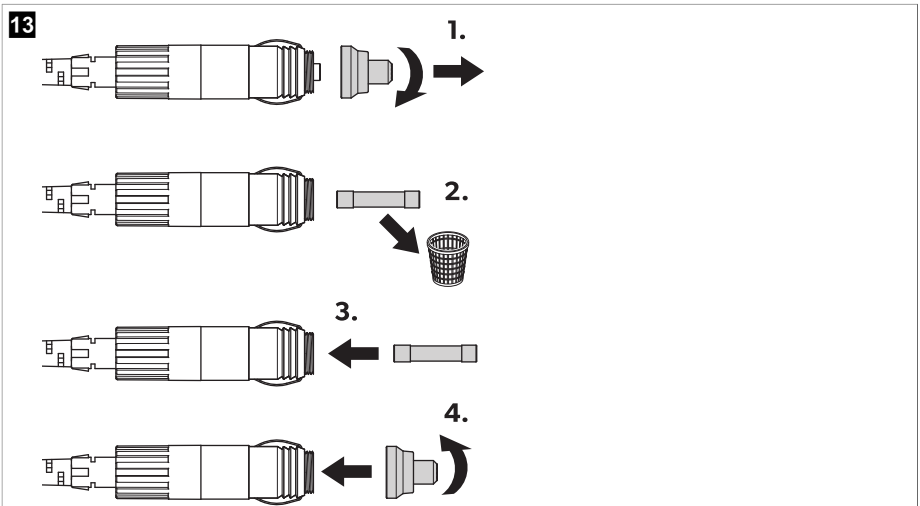

## 9.15 Replacing the light PCB



### NOTICE! Damage hazard

The lamp can only be replaced by the manufacturer, a service agent; or similarly qualified person to avoid hazard.

## 10 Cleaning and maintenance



### CAUTION! Electrocutation hazard

Ensure that the cooling device is disconnected from the power supply before any cleaning or maintenance work.



### NOTICE! Damage hazard

- > Never clean the cooling device under running water or in dish water.
- > Do not use abrasive cleaning agents or hard objects during cleaning.

- > Occasionally clean the device interior and exterior with a damp cloth.
- > Ensure that the air inlet and outlet vents on the cooling device are free of any dust and dirt, so that heat can be released and the cooling device is not damaged.

## 11 Troubleshooting

Problem	Possible cause	Suggested remedy
Device does not function, LED does not glow.	No voltage present in the connected power outlet.	<ol style="list-style-type: none"> <li>1. Plugged in DC power outlet: In most vehicles the ignition must be turned on before power will be supplied to the DC power outlet.</li> <li>2. Plugged in AC power outlet: Try using another plug outlet.</li> </ol>
	One of the device fuses is defective.	> Replace the defective device fuse, see Replacing the AC fuse on page 22 or Replacing the DC fuse on page 22.
	The integrated AC adapter is defective.	This can only be repaired by an authorized repair center.
The device does not cool (plug is inserted, LED is lit).	Defective compressor.	This can only be repaired by an authorized repair center.
The device does not cool (plug is inserted, LED flashes orange, display is switched off).	Battery monitor is set too high.	> Select a lower battery monitor setting.
	Battery voltage is too low.	> Test the battery and charge it as needed.
When operating from the DC outlet: The ignition is on and the device is not working and the LED is not lit.	The DC outlet is dirty. This results in a poor electrical contact.	> If the plug of the cooling device becomes very warm in the DC outlet, either the DC outlet must be cleaned or the plug has not been assembled correctly.
	The fuse of the DC plug has blown.	> Replace the fuse in the DC plug, see Replacing the DC plug fuse on page 22.

Problem	Possible cause	Suggested remedy
	The device DC fuse has blown.	> Replace the defective fuse, see Replacing the DC fuse on page 22.
	The vehicle fuse has blown.	> Replace the vehicle's DC outlet fuse. Please refer to your vehicle's operating manual.
The display shows an error message (e.g., "Err1") and the appliance does not cool.	The appliance has switched off due to an internal fault.	This can only be repaired by an authorized repair center.

**Lid past built-in stop (CFF35, CFF45)**



**CAUTION! Risk of injury**

Beware pinching your thumb while closing the lid.



**NOTICE! Damage hazard**

Failure to observe these instructions can cause the lid to break off.

If the lid has been forced past the built-in stop, proceed as follows (  Fig. 14 on page 24):

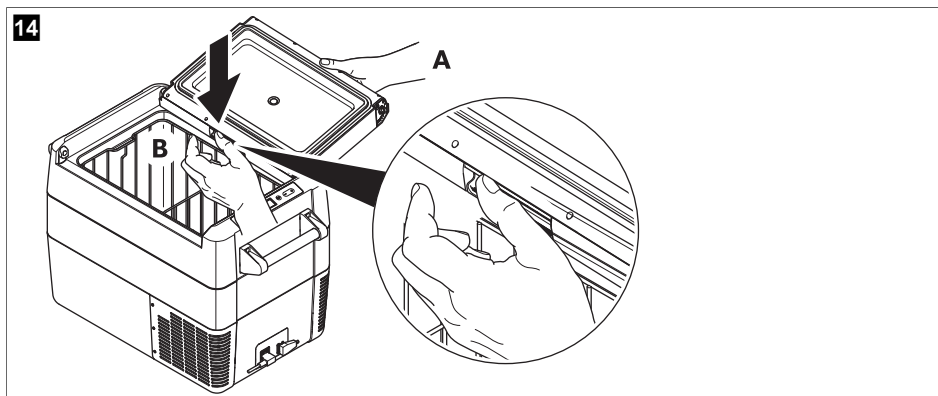

- Support the lid with one hand (A).
- Hold the latch down with the other hand (B).
- Close the lid as far as possible without pinching your thumb, while still holding the latch down, to keep it from breaking.
- The lid should now be approximately at the angle shown (fig. e, page 12).
- Remove the hand from the latch (B), and continue closing the lid all the way.



**NOTE** The hinges may release from the correct position during the final closing action. Reposition the lid as follows:

- Operate the latches on both sides of the lid simultaneously.
- Lift and reposition the lid.



## 12 Warranty

If the product does not work as it should, please contact your retailer or the manufacturer's branch in your country (see [dometic.com/dealer](http://dometic.com/dealer)). The warranty applicable to your product is 3 year(s).

For repair and warranty processing, please include the following documents when you send in the device:

- A copy of the receipt with purchasing date
- A reason for the claim or description of the fault

Note that self-repair or nonprofessional repair can have safety consequences and might void the warranty.

### Australia only

Our goods come with guarantees that cannot be excluded under the Australian Consumer Law. You are entitled to a replacement or refund for a major failure and for compensation for any other reasonably foreseeable loss or damage. You are also entitled to have the goods repaired or replaced if the goods fail to be of acceptable quality and the failure does not amount to a major failure.

### New Zealand only

This warranty policy is subject to the conditions and guarantees which are mandatory as implied by the Consumer Guarantees Act 1993(NZ).

### Local support

Please find local support at the following link address: [dometic.com/dealer](http://dometic.com/dealer)

## 13 Disposal



Recycling packaging material: Place the packaging material in the appropriate recycling waste bins wherever possible.



Recycling products with non-replaceable batteries, rechargeable batteries, or light sources:

- If the product contains any non-replaceable batteries, rechargeable batteries, or light sources, you don't have to remove them before disposal.
- If you wish to finally dispose of the product, ask your local recycling center or specialist dealer for details about how to do this in accordance with the applicable disposal regulations.

## 14 Technical data

The refrigeration circuit contains a small quantity of an environmentally friendly but flammable refrigerant. It does not damage the ozone layer and does not increase the greenhouse effect. Any leaking refrigerant may ignite.

	<b>CFF12</b>
Total volume	13 L
Connection voltage	12 V <sup>===</sup> / 24 V <sup>===</sup>
	100 V <sup>~</sup> ... 240 V <sup>~</sup>
Rated current 12 V <sup>===</sup> (R134a)	6 A
Rated current 12 V <sup>===</sup> (R600a)	5.6 A
Rated current 24 V <sup>===</sup> (R134a)	3.3 A
Rated current 24 V <sup>===</sup> (R600a)	2.5 A

	<b>CFF12</b>
Rated current 240 V~ @ 50 Hz (R134a)	0.35 A
Rated current 240 V~ @ 50 Hz (R600a)	0.52 A
Refrigerant	R134a or R600a (see type label)
Cooling capacity (R134a)	10°C ... -18°C
Cooling capacity (R600a)	20°C ... -18°C
Climate class	N, T
Ambient temperature	16°C ... 43°C
CO <sub>2</sub> equivalent	0.037 t (R134a)
Global warming potential (GWP)	1430 (R134a)
Refrigerant volume (R134a)	26 g
Refrigerant volume (R600a)	10 g
Dimensions (W x H x D) without handles	562 mm x 380 mm x 235 mm
Weight	9.6 kg
Certificates	

	<b>CFF18</b>
Total volume	19 L
Connection voltage	12 V== / 24 V== 100 V~ ... 240 V~
Rated current 12 V==	4.5 A
Rated current 24 V==	2.1 A
Rated current 240 V~	0.5 A
Cooling capacity	20°C ... -18°C
Climate class	N, T
Ambient temperature	16°C ... 43°C
Refrigerant	R134a or R600a (see type label)
Refrigerant volume (R134a)	20 g
Refrigerant volume (R600a)	10 g
CO <sub>2</sub> equivalent	0.029 t (R134a)
Global warming potential (GWP)	1430 (R134a)
Dimensions	
W x H x D (including handles)	508 mm x 525 mm x 300 mm (handle up)
W x H x D (without handles)	508 mm x 422 mm x 316 mm
Weight	10.4 kg

	<b>CFF18</b>
Certificates	

	<b>CFF20</b>
Total volume	21 L
Connection voltage	12 V <sup>===</sup> / 24 V <sup>===</sup>
	100 V <sup>~</sup> ... 240 V <sup>~</sup>
Rated current 12 V <sup>===</sup> (R134a)	6.5 A
Rated current 12 V <sup>===</sup> (R600a)	5.6 A
Rated current 24 V <sup>===</sup> (R134a)	3.4 A
Rated current 24 V <sup>===</sup> (R600a)	2.5 A
Rated current 240 V <sup>~</sup> @ 50 Hz (R134a)	0.38 A
Rated current 240 V <sup>~</sup> @ 50 Hz (R600a)	0.52 A
Cooling capacity	20°C ... -18°C
Climate class	N, T
Ambient temperature	16°C ... 43°C
Refrigerant	R134a or R600a (see type label)
Refrigerant volume (R134a)	28 g
Refrigerant volume (R600a)	10 g
CO <sub>2</sub> equivalent	0.040 t (R134a)
Global warming potential (GWP)	1430 (R134a)
Dimensions	
W x H x D (including handles)	660 mm x 430 mm x 283 mm (handle up)
W x H x D (without handles)	533 mm x 430 mm x 283 mm
Weight	11.3 kg
Certificates	

	<b>CFF35</b>
Total volume	34 L
Connection voltage	12 V <sup>===</sup> / 24 V <sup>===</sup>
	100 V <sup>~</sup> ... 240 V <sup>~</sup>
Rated current 12 V <sup>===</sup> (R134a)	7.8 A
Rated current 12 V <sup>===</sup> (R600a)	6.5 A
Rated current 24 V <sup>===</sup> (R134a)	3.5 A
Rated current 24 V <sup>===</sup> (R600a)	3 A
Rated current 240 V <sup>~</sup> @ 50 Hz (R134a)	0.4 A

	<b>CFF35</b>
Rated current 240 V~ @ 50 Hz (R600a)	0.54 A
Cooling capacity (R134a)	10°C ... -18°C
Cooling capacity (R600a)	20°C ... -18°C
Climate class	N, T
Ambient temperature	16°C ... 43°C
Refrigerant	R134a or R600a (see type label)
Refrigerant volume (R134a)	34 g
Refrigerant volume (R600a)	14 g
CO <sub>2</sub> equivalent	0.049 t (R134a)
Global warming potential (GWP)	1430 (R134a)
Dimensions	
W x H x D (including handles)	704 mm x 407 mm x 398 mm
W x H x D (without handles)	590 mm x 407 mm x 398 mm
Weight	16.5 kg
Certificates	

	<b>CFF45</b>
Total volume	44 L
Connection voltage	12 V== / 24 V==
	100 V~ ... 240 V~
Rated current 12 V== (R134a)	8.6 A
Rated current 12 V== (R600a)	6.7 A
Rated current 24 V== (R134a)	3.8 A
Rated current 24 V== (R600a)	3 A
Rated current 240 V~ @ 50 Hz (R134a)	0.41 A
Rated current 240 V~ @ 50 Hz (R600a)	0.55 A
Cooling capacity (R134a)	10°C ... -18°C
Cooling capacity (R600a)	20°C ... -18°C
Climate class	N, T
Ambient temperature	16°C ... 43°C
Refrigerant	R600a or R134a (see type label)
Refrigerant volume (R134a)	43 g
Refrigerant volume (R600a)	15 g
CO <sub>2</sub> equivalent	0.061 t (R134a)
Global warming potential (GWP)	1430 (R134a)

	<b>CFF45</b>
Dimensions	
W x H x D (including handles)	704 mm × 475 mm × 398 mm (handle up)
W x H x D (without handles)	590 mm × 475 mm × 398 mm
Weight	17.8 kg
Certificates	

	<b>CFF50LPDZ</b>
Total volume	50 L
Connection voltage	12 V <sup>===</sup> / 24 V <sup>===</sup> 100 V <sup>~</sup> ... 240 V <sup>~</sup>
Rated current 12 V <sup>===</sup>	6.8 A
Rated current 24 V <sup>===</sup>	3.1 A
Rated current 240 V <sup>~</sup>	0.58 A
Cooling capacity	20°C ... -18°C
Climate class	N, T
Ambient temperature	16°C ... 43°C
Refrigerant	R600a
Refrigerant volume	13 g (R600a)
Dimensions	
W x H x D (including handles)	903 mm × 407 mm × 443 mm (handle up)
W x H x D (without handles)	785 mm × 407 mm × 443 mm
Weight	20.5 kg
Certificates	

	<b>CFF70DZ</b>
Total volume	70 L (30 L/40 L)
Connection voltage	12 V <sup>===</sup> / 24 V <sup>===</sup> 100 V <sup>~</sup> ... 240 V <sup>~</sup>
Rated current 12 V <sup>===</sup> (R134a)	9 A
Rated current 12 V <sup>===</sup> (R600a)	7 A
Rated current 24 V <sup>===</sup> (R134a)	4 A
Rated current 24 V <sup>===</sup> (R600a)	3.2 A
Rated current 240 V <sup>~</sup> @ 50 Hz (R134a)	0.44 A
Rated current 240 V <sup>~</sup> @ 50 Hz (R600a)	0.6 A
Cooling capacity	20°C ... -18°C

	<b>CFF70DZ</b>
Climate class	N, T
Ambient temperature	16°C ... 43°C
Refrigerant	R134a or R600a (see type label)
Refrigerant volume (R134a)	34 g
Refrigerant volume (R600a)	14 g
CO <sub>2</sub> equivalent	0.049 t (R134a)
Global warming potential (GWP)	1430 (R134a)
Dimensions	
W x H x D (including handles)	903 mm × 500 mm × 443 mm (handle up)
W x H x D (without handles)	785 mm × 500 mm × 443 mm
Weight	25.6 kg
Certificates	



**NOTE** If the ambient temperature is above 32°C, the minimum temperature cannot be attained.

R134a is a fluorinated greenhouse gas.

The cooling unit is hermetically sealed.





[dometic.com](https://dometic.com)

---

## **YOUR LOCAL DEALER**

[dometic.com/dealer](https://dometic.com/dealer)

## **YOUR LOCAL SUPPORT**

[dometic.com/contact](https://dometic.com/contact)

## **YOUR LOCAL SALES OFFICE**

[dometic.com/sales-offices](https://dometic.com/sales-offices)

---